

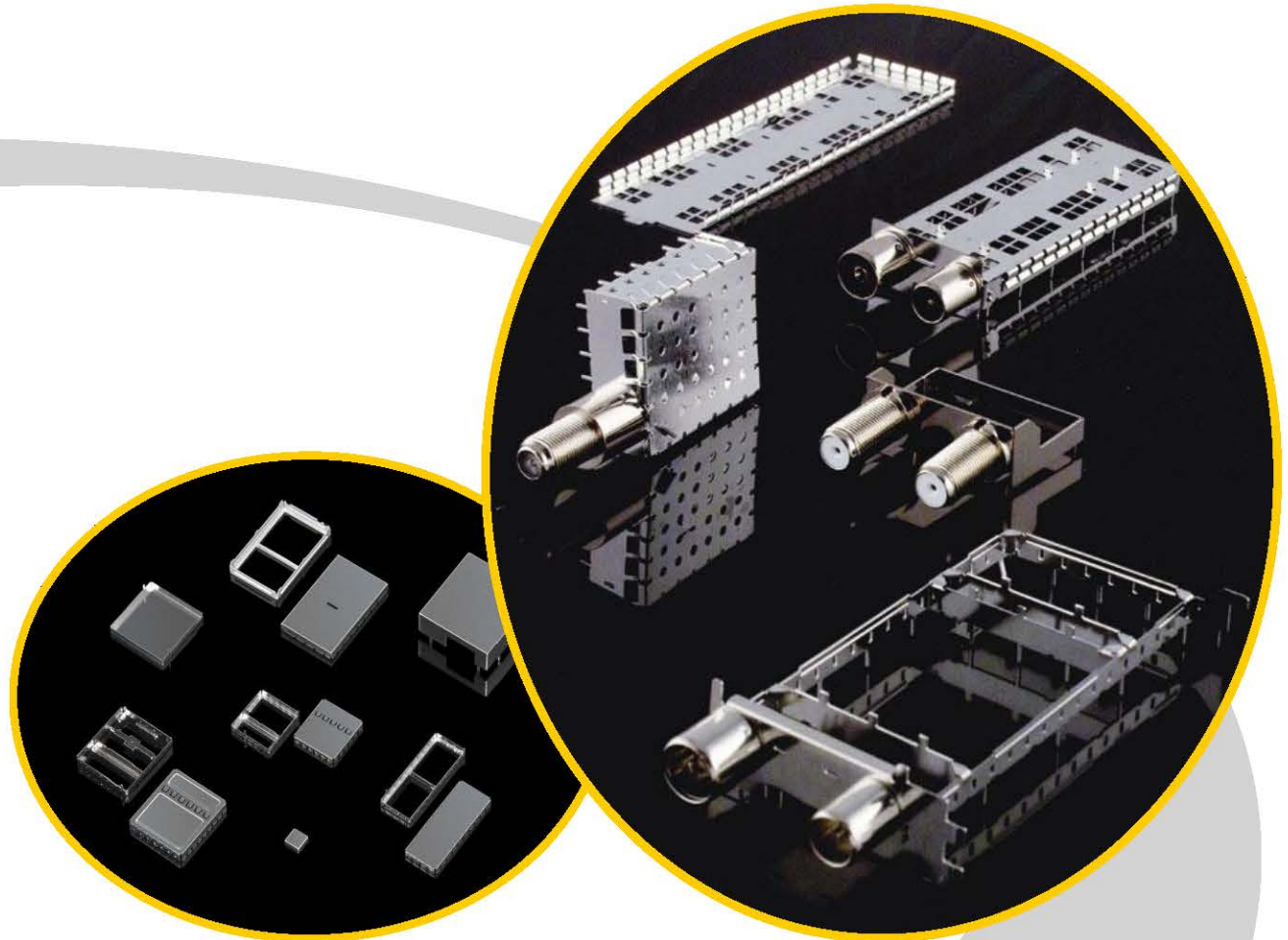

DUPLEX CSA

# Custom Metalwork Division

## RF Shielding Product



### Custom EMI/RFI Shielding

Today's electronic devices are extremely susceptible to high frequency and electromagnetic interference. Duplex shielding products are designed to protect sensitive components from RF (radio frequency) electromagnetic radiation by keeping it contained inside or sealed out of a device.

In partnership with our metalwork division, Duplex CSA has made a major investment in the design and fabrication of custom shielding products that complement our connector portfolio. This means we can offer fast turn around from design to delivery of completed components.

Duplex can deliver solutions ranging from a single piece shield to complex multi compartment cases with snap on covers. An idea can be turned into reality fast with minimum cost, utilising a range of standard features that are tooled and ready to use.

Duplex CSA has the expertise to provide you with complete RF/EMI shielding solutions for all of your PCB needs, from prototypes to volume production.

Standard or custom applications, Duplex CSA is ready to assist you with your design requirements.

# Standard Design Features and Options:

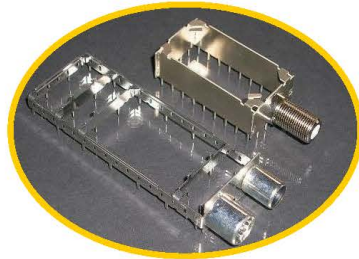
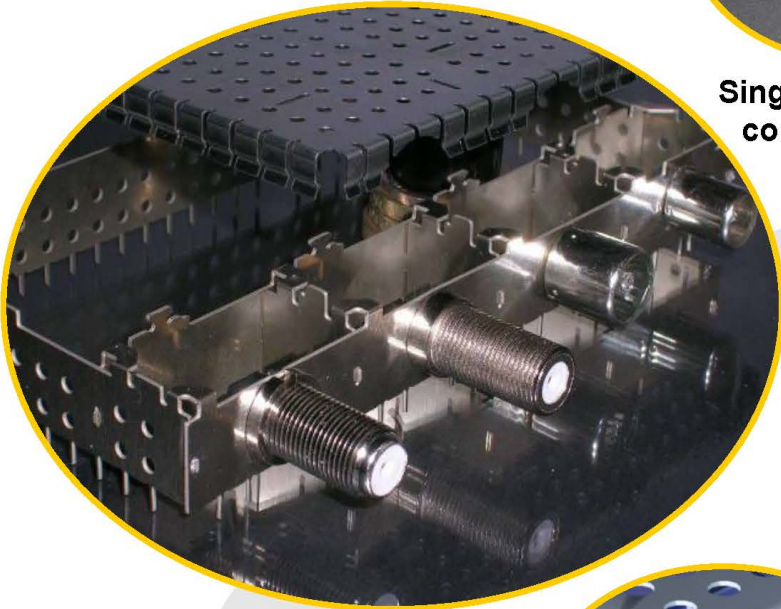

Single or multiple compartments

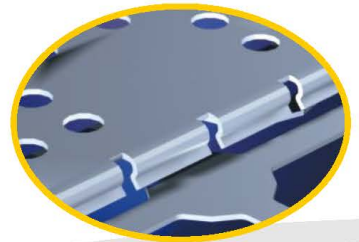

Locations for vacuum pick & place

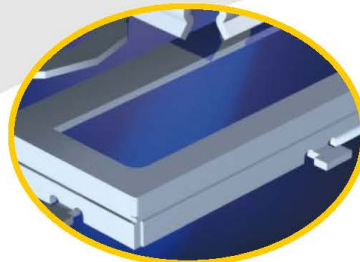

SMT solder pads and grounding points



Peel off lids have a solid top with etched lines that allow access to PCB level components when necessary

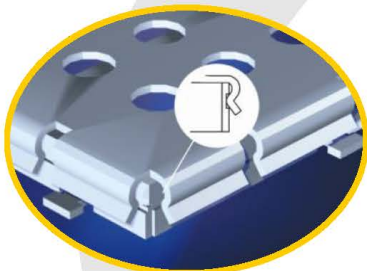

Snap fit covers, with spring fingers for multiple point grounding



Through hole or PIHR solder Contacts



Custom marking can be added

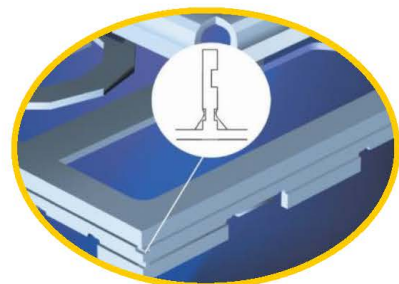

Solder wells prevent migration of solder



Anti rotational feature for connectors

These features are available as tooled options immediately available to be incorporated into any design and can be produced by photo etching techniques. If your design moves on to be tooled with press tooling some variations may have to be applied.

## F - Type Connectors

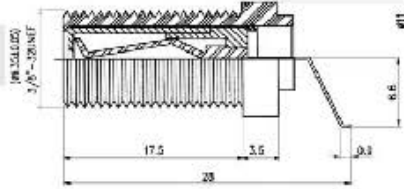

**F and TV Connectors can be swaged onto a shield frame. Male and female connectors are available with SMT or through hole terminations. If you need alternative configurations please call us to discuss your requirements**

## IEC - TV Connectors

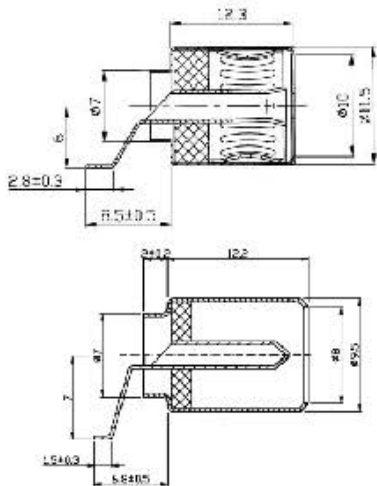

**Are you looking for something out of the ordinary?**

**The options are only limited by your imagination.**

**Give us a call to discuss making your ideas a reality.**



## Prototypes:

Prototypes and production runs can be produced quickly and with minimum tooling costs using photo etching techniques. By incorporating our standard features into your design we can keep tooling and set up charges to a minimum.

Photo etching is an economical way to produce & prove prototype designs as well as going on to produce final production quantities.

## Materials we would typically recommend:

**Shield Frame:** Nickel Silver NS 106 Half hard, 0.406mm thick

**Shield lid:** Nickel Silver NS 106 Half hard, 0.254mm thick

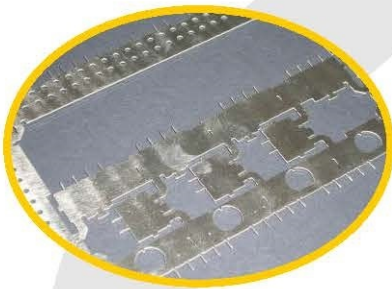

Your design is converted into a developed shape and etched from nickel silver sheet



The sheet is folded & staked, spot welded or soldered to give a completed shield frame



Connectors are fitted and swaged into place



Completed shield frame



## DUPLEX CSA LTD

Tel: +44 1480 406206  
Email: [sales@duplexcsa.com](mailto:sales@duplexcsa.com)  
[www.duplexcsa.com](http://www.duplexcsa.com)

